

Analog Devices Welcomes Hittite Microwave Corporation

NO CONTENT ON THE ATTACHED DOCUMENT HAS CHANGED



THIS PAGE INTENTIONALLY LEFT BLANK

The information provided in this document is for a product controlled by the International Traffic in Arms Regulations (ITAR). This product cannot be shipped outside of the United States without a U.S. Department of State export license.

Typical Applications

- Satellite communications
 - Commercial
 - Military

General Description

The HMC7054 is a fully integrated Ka-Band HPA. The unit is designed for single carrier use in satellite communications. It covers both Commercial and Military bands and is designed to meet military environmental conditions.

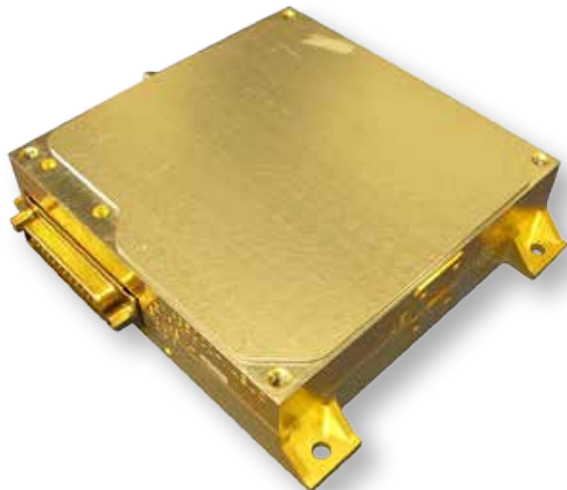

Features

- Compact Design
- WR28 Output with Isolator
- PA Enable
- Thermal Monitoring and Gain Compensation
- Size: 5.0" x 4.51" x 1.145"
- Weight: 1.6 lbs.
- Designed for Military Environments

Parameter	Typical
Frequency Range (GHz)	29 - 31
Small Signal Gain (dB)	42
Gain Flatness - 1 GHz (dB)	3
Gain Flatness - 10 MHz (dB)	0.7
Input Power (dBm)	0
Output Linear Power (PSK) (dBm)	+37
Spurious (dBc)	-60
AM/PM Conversion (Deg/dB)	2
HPA DC Power (VDC @ AMP)	5.0V @ 14.0 A
Size (in)	5.0" x 4.51" x 1.145"

Functional Block Diagram

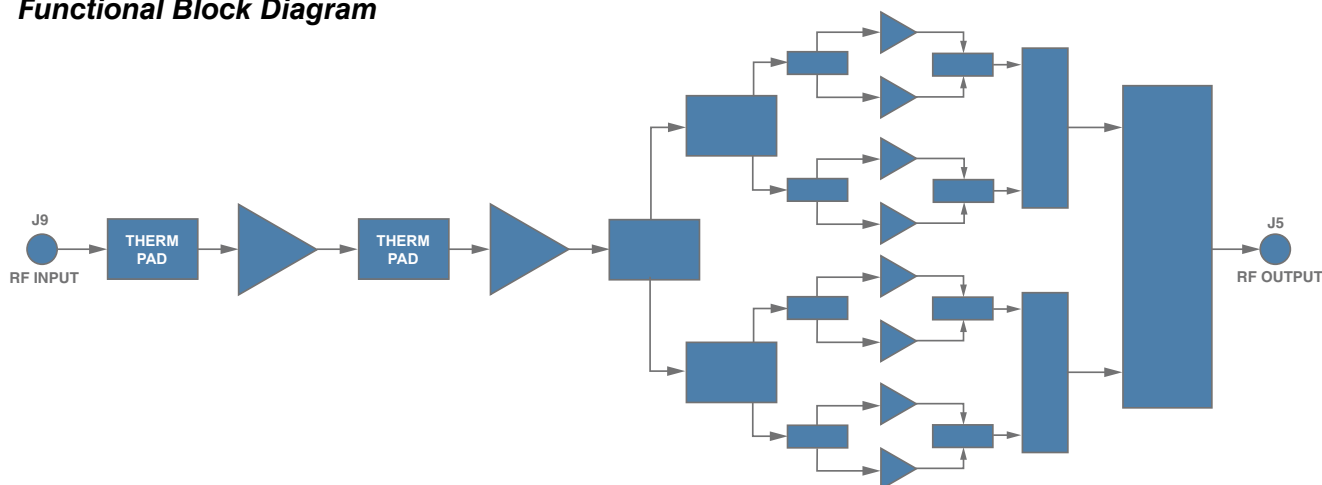

The information provided in this document is for a product controlled by the International Traffic in Arms Regulations (ITAR). This product cannot be shipped outside of the United States without a U.S. Department of State export license.

Electrical Specifications

Parameter	Specification			Units	Notes
	Min.	Typ.	Max.		
Frequency range (MIL)	30		31	GHz	Military band
Frequency range (COMM)	29		30	GHz	Commercial band
Reference frequency		10		MHz	
Reference output power	-7.5		5	dBm	
Input Power			5	dBm	
Small Signal gain	42		42	dB	
Gain flatness -1Ghz			3	dB	
Gain flatness -40Mhz			0.7	dB	
Gain variation (over temp)			±1.0	dB	
Gain stability			±0.25	dB/24h	
Group delay - 40MHz			±0.25	nSec	
Group delay - 10MHz			±0.1	nSec	
Input (VSWR)		2:1			
RF output (VSWR)		1.5:1			With external Isolator
Linear power		37		dBm	PSK
P1dB		38.5		dBm	
TX maximum power (P _{sat})		39.5		dBm	3dB compression
Output IP3		47.5		dBm	
Power added efficiency	8			%	
Signal related spurious			-60	dBc	
Non-signal related spurs			-40	dBm	
TX single sideband spurs			-40	dBm	
AM/PM conversion	0		2	Deg/dB	
PA mute attenuation	40			dB	
PA mute settling time		50	150	µs	
VDD (HPA)	4.9		5.1	VDC	
-5V	-5.1		-4.9	VDC	
I (-5V)			75	mA	
IDD (HPA)			14.3	A	
DC power Max (RF)			89	W	
DC power (HPA mute)			21	W	
HPA Temp sense	0		0.78	V	
VDD_HPA_SENSE/RTN	4.9		5.1	V	

The information provided in this document is for a product controlled by the International Traffic in Arms Regulations (ITAR). This product cannot be shipped outside of the United States without a U.S. Department of State export license.

Figure 1. Small Signal Gain

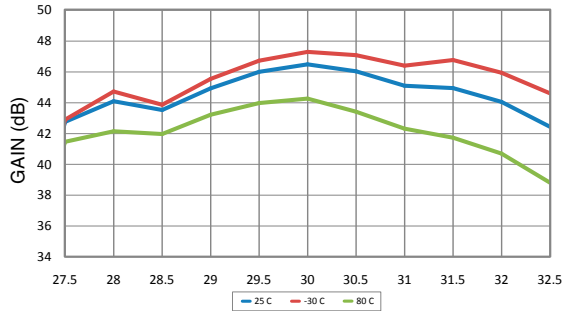

Figure 2. Output P1dB & PAE

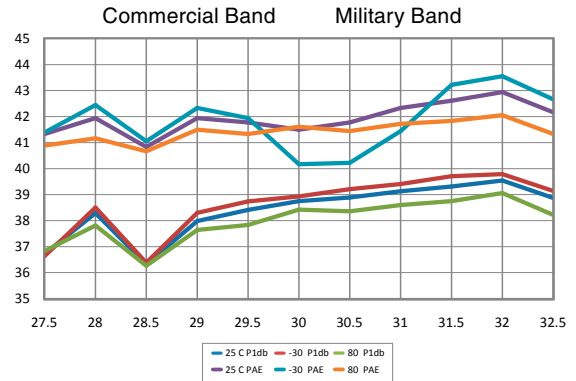

Figure 3. Saturated Output Power

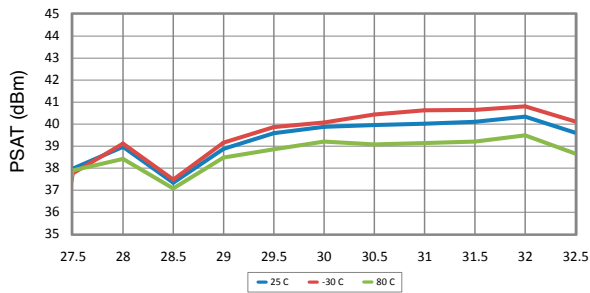

Figure 4. Linear Power (SRG)

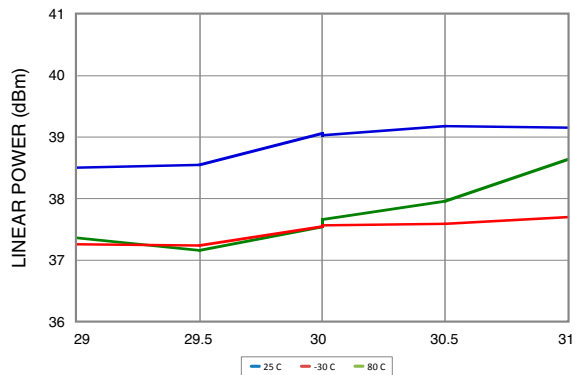

Figure 5. IP3

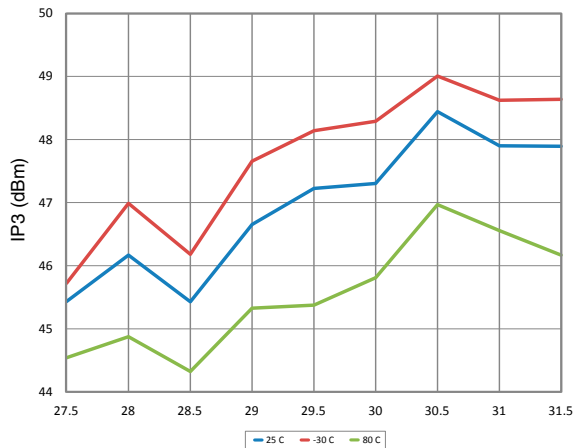
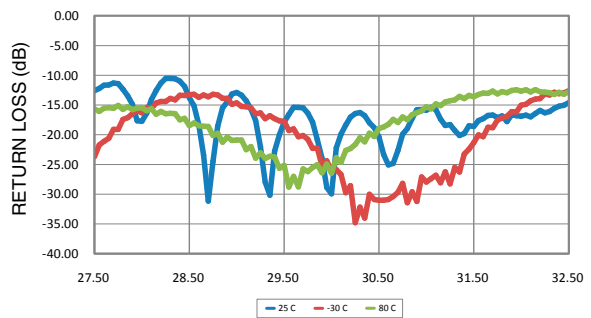

Figure 6. Input Return Losses



The information provided in this document is for a product controlled by the International Traffic in Arms Regulations (ITAR). This product cannot be shipped outside of the United States without a U.S. Department of State export license.

Figure 7. Output Return Losses (Military Band)

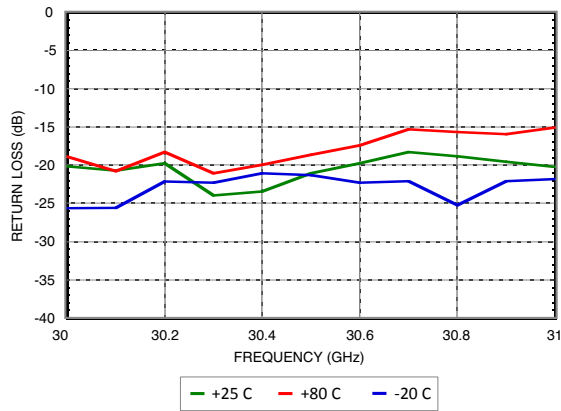
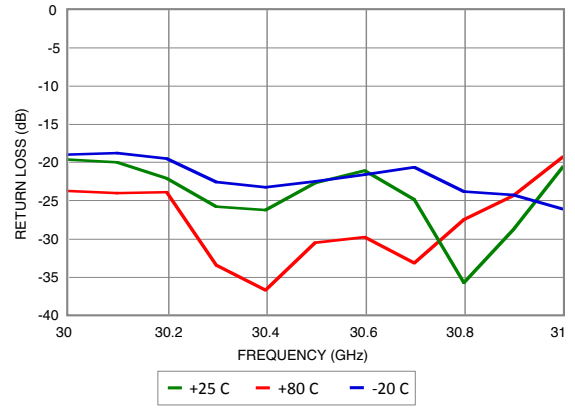

Figure 8. Output Return Losses (Commercial Band)



The information provided in this document is for a product controlled by the International Traffic in Arms Regulations (ITAR). This product cannot be shipped outside of the United States without a U.S. Department of State export license.

Table 1. Absolute Maximum Ratings

Parameter	Max Rating
VDD_HPA	+5.5V
-5 VDC_HPA	-6V
Operating temp	-20 to +80 °C
Storage temp	-55 to +125 °C
Continuous Pdiss	70W
ESD sensitivity	Class 1A

Table 2. RF I/O Port

Port #	I/O	Function	Description
J5	O	HPA_RF_OUT	Unit RF output port (WR28)
J9	O	HPA_RF_IN	Power amplifier module (HPA) RF input port K(F)

Table 3. J1 HPA Connector Pin Out

Pin #	Signal/Voltage	Description
1	VDD_HPA	HPA drain Voltage
2	VDD_HPA	
3	VDD_HPA	
4	VDD_HPA	
5	VDD_HPA	
6	VDD_HPA	
7	VDD_HPA	
8	-5 VDC	HPA gate Voltage
9	GND	
10	VDD_HPA_SENSE_RTN	Ground
11	PV_SEQ_READY	Voltage sequence ready indicator. Low (-3.5V): unit ready to apply VDD. High (0V): unit not read
12	BUC_HPA_I2C_SDA	I ² C temperature sensor
13	GND	
14	GND	
15	GND	
16	GND	
17	GND	
18	GND	
19	GND	
20	GND	
21	TEMP_SENSE	Unit temperature (analog)
22	VDD_HPA_SENSE	Positive voltage sensed at unit DC port
23	HPA_MUTE	Output stage amplifier pinch off. High (3.3V): HPA mute, Low (0V): HPA enable
24	GND	
25	BUC_HPA_I2C_SCL	I ² C temperature sensor

The information provided in this document is for a product controlled by the International Traffic in Arms Regulations (ITAR). This product cannot be shipped outside of the United States without a U.S. Department of State export license.

Table 4. J2 BUC Connector Pin Out

Pin #	Signal/Voltage	Description
1	VDD_BUC	BUC positive voltage supply
2	VDD_BUC	
3	VDD_BUC	
4	21VDC	BUC positive voltage supply to PLLs
5	GND	
6	SPARE	
7	MDM_SELECT	Modem input selection. High (3.3V): internal modem, Low (0V): external modem
8	BUC_LO_LOCK	PLL lock indication. High (3.3V): unlocked, Low (0V): locked
9	TX_GAIN_CNTL_LE	Gain control signal latch enable
10	GND	
11	RESERVED FOR VENDOR USE: (RS232_RXD0)	
12	BUC_HPA_12C_SDA	I ² C bus data
13	GND	
14	GND	
15	GND	
16	GND	
17	-5VDC	BUC negative voltage supply
18	HPA_MUTE	
19	GND	
20	TX_BAND_SELECT	Transmitter band selection. High (3.3V): commercial band 29-30GHz, Low (0V): military band 30-31GHz
21	TX_GAIN_CNTL_SERIN	Gain control signal serial input
22	TX_GAIN_CNTL_CLK	Gain control signal clock
23	RESERVED FOR VENDOR USE: (RS232_RXD0)	
24	GND	
25	BUC_HPA_12C_SCL	I ² C bus clock

The information provided in this document is for a product controlled by the International Traffic in Arms Regulations (ITAR). This product cannot be shipped outside of the United States without a U.S. Department of State export license.

Outline Drawing

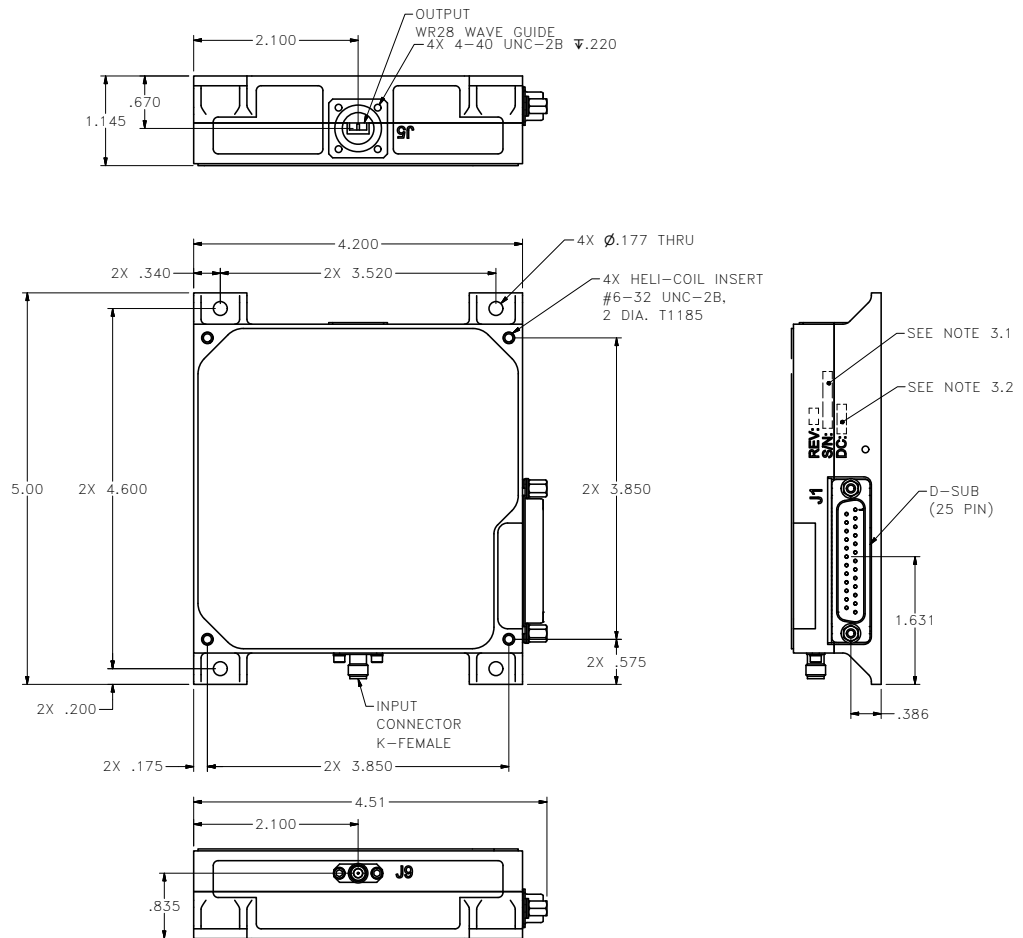

- NOTES:
- 1.0 MATERIAL: ALUMINUM
 - 2.0 FINISH: SILVER PER ASTM B700 OVER NICKEL PER MIL-C-26074
 - 3.0 PRODUCT MARKINGS TO BE ENGRAVED AND LOCATE APPROXIMATELY AS SHOWN
 - 3.1 UNIT TO BE SERIALLY MARKED IN ACCORDANCE WITH PURCHASE CONTRACT WHERE "X" = SEQUENTIAL NUMBERS
 - 3.2 DATE COE MARKING TO SHOW DATE IN "MMYY" FORMAT

Package Information

Size	Weight
5.0" x 4.51" x 1.145"	1.6 lbs.

